

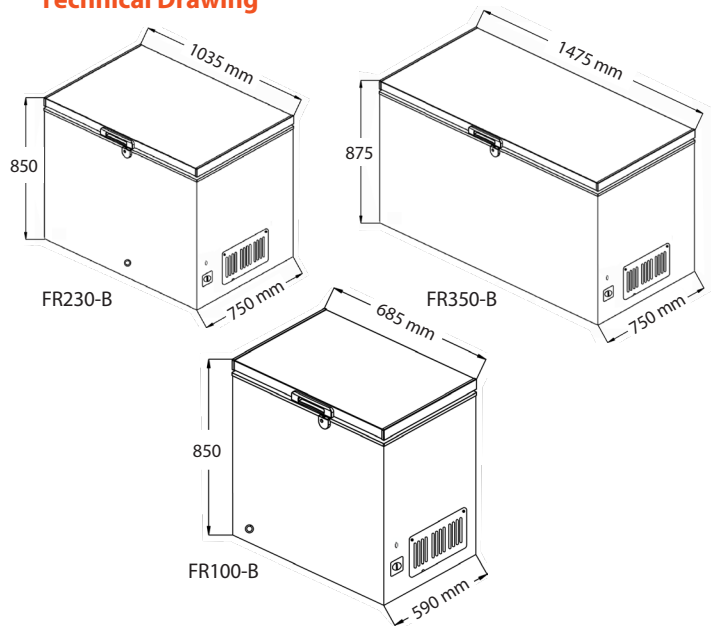

Technical Drawing



Product Features

- New Feature: BOOST switch for faster cooling
- Works as a refrigerator or freezer with adjustable thermostat
- Does not require an inverter
- Intuitive setup including simple 2-wire DC connection
- High-efficiency cooling
- Environmentally-friendly R600a refrigerant
- Hanging basket(s) included for better space utilization
- Lockable lid

Product Introduction

The Phocos FR-B Series DC chest refrigerator/freezer with BOOST feature offers the most flexible solution for off-grid and edge-of-grid refrigeration in the market today. The unique BOOST feature provides the ability to choose between best cooling performance and highest efficiency to serve a variety of uses. In the field, all models can be used with 12 V or 24 V batteries, and can operate as a refrigerator or freezer by simply adjusting the thermostat.

The FR-B Series has been designed to maximize reliability by utilizing a maintenance-free brushless DC compressor for direct connection to a battery and long-lasting mechanical thermostat. An aluminum inner-lining and drain plug allow for easy clean up. FR-B refrigerator/freezers are also internally protected against low voltage and reverse polarity conditions.

Technical Data

Type	FR100-B	FR230-B	FR350-B
System Voltage (Nominal)	12 / 24 V auto recognition		
Internal Operating Temperature Range	-18 to +8 °C / -0.4 to +46.4 °F		
Energy Consumption at 21°C / 70°F Ambient Temperature (in Default ECO Mode)	82 Wh / day (Fridge: 4 °C / 38 °F) 433 Wh / day (Freezer: -18 °C / 0 °F)	178 Wh / day (Fridge: 4 °C / 38 °F) 609 Wh / day (Freezer: -18 °C / 0 °F)	202 Wh / day (Fridge: 4 °C / 38 °F) 679 Wh / day (Freezer: -18 °C / 0 °F)
Energy Consumption at 32°C / 90°F Ambient Temperature (in Default ECO Mode)	174 Wh / day (Fridge: 4 °C / 38 °F) 561 Wh / day (Freezer: -18 °C / 0 °F)	193 Wh / day (Fridge: 4 °C / 38 °F) 899 Wh / day (Freezer: -18 °C / 0 °F)	228 Wh / day (Fridge: 4 °C / 38 °F) 981 Wh / day (Freezer: -18 °C / 0 °F)
Content (Net Capacity)	104 L / 3.6 cu. ft	238 L / 8.4 cu. ft	358 L / 12.6 cu. ft
Refrigerant	Environmentally-Friendly R600a		
Ambient Temperature	+10 to +43 °C / +50 to +104 °F		
Door Type	Top-Opening with integrated handle and lock		
Storage Baskets	1 Basket	2 Baskets	3 Baskets
Boost Switch	Standard on all models - accelerates cooling when activated		
Cabinet Dimensions (WxHxD)	685 x 850 x 590 mm / 27 x 33.5 x 23.2 in	1035 x 850 x 750 mm / 40.8 x 33.5 x 29.5 in	1475 x 875 x 750 mm / 58.1 x 34.5 x 29.5 in
Inner Dimensions (WxHxD)	505 x 640 x 375 mm / 19.9 x 25.2 x 14.8 in Excludes compressor recess of 190 x 210 x 375 mm / 7.5 x 8.3 x 14.8 in	628 x 856 x 496 mm / 24.7 x 33.7 x 19.5 in Excludes compressor recess of 250 x 230 x 496 mm / 9.8 x 9.1 x 19.5 in	619 x 1290 x 498 mm / 24.4 x 50.8 x 19.6 in Excludes compressor recess of 240 x 300 x 498 mm / 9.4 x 11.8 x 19.6 in
Weight	29 kg / 64 lbs	80 kg / 160 lbs	110 kg / 242 lbs
Container Loading (20' / 40' GP / 40' HC)	54 pcs. / 108 pcs. / 170 pcs.	30 pcs. / 60 pcs. / 98 pcs.	20 pcs. / 42 pcs. / 66 pcs.
Warranty	2 years		